

Technical Overview

Features

- Complete millimeter wave receiver and antenna
- 57 to 64 GHz unlicensed band
- 5 dB system noise figure typical
- 500 MHz baseband channels
- I/Q, AM, FM detectors
- > 1.5 GHz detection bandwidth at 60 GHz
- On chip synthesizer covers 57.0 to 63.0 GHz with 0.5 GHz step size
- Reference clock 285.714 MHz
- Internal high efficiency antenna
- Antenna gain > 12 dBi typical
- Low-loss millimeter wave radome
- 81-pin BGA package – 10 mm x 10 mm x 4 mm

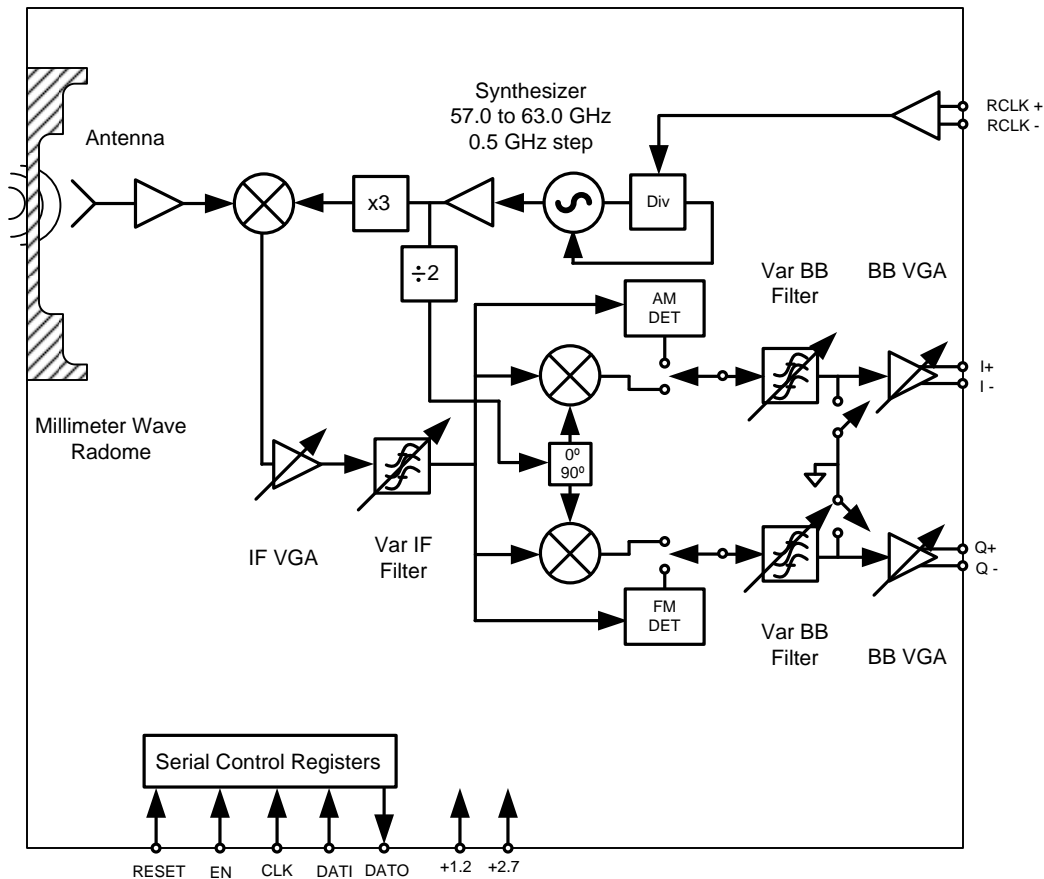

Rev 1.0

65 Enterprise
Aliso Viejo, CA 92656, U.S.A
Telephone 949-226-8482
FAX 815-572-0386

www.vubiq.com
© 2008 Vubiq, Inc. All rights reserved.

Information furnished by Vubiq is believed to be accurate and reliable. However, no responsibility is assumed by Vubiq for its use, nor for any infringements of patents or other rights of third parties that may result from its use. Specifications subject to change without notice. No license is granted by implication or otherwise under any patent or patent rights of Vubiq. Trademarks and registered trademarks are the property of their respective owners.

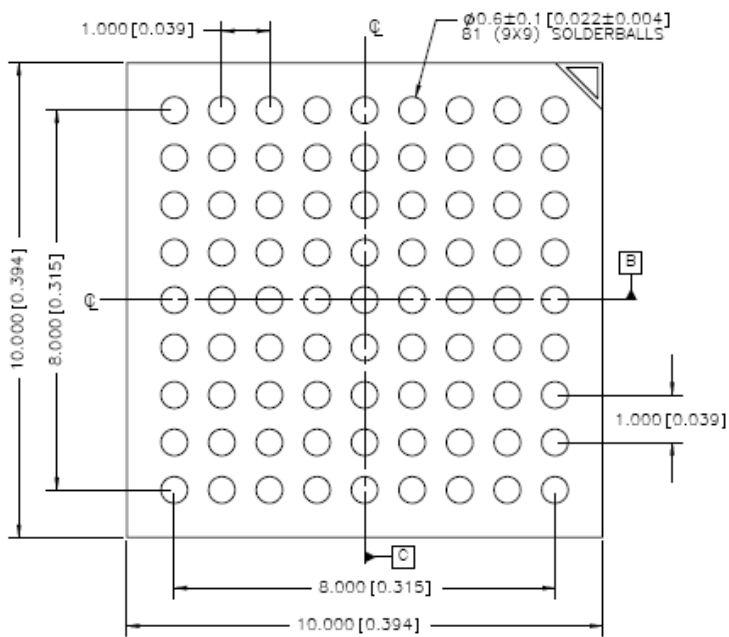
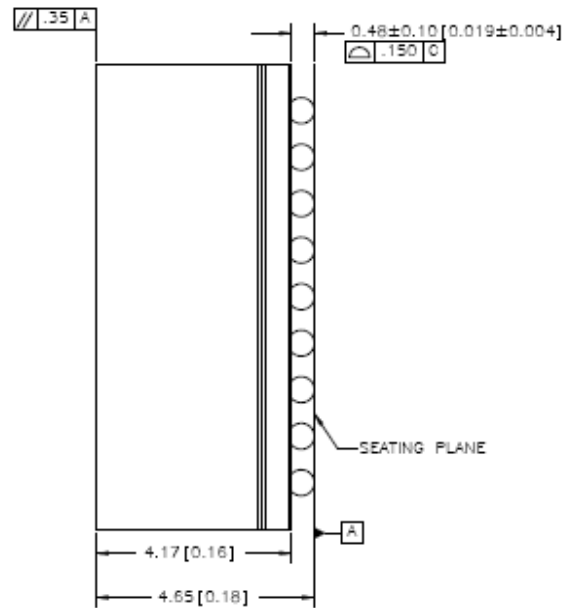
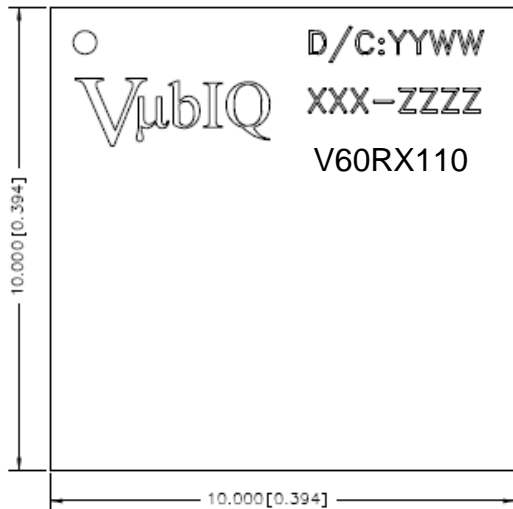

BGA Package Dimensions

A1	GND
A2	+1.2
A3	GND
A4	RCLK-
A5	RCLK+
A6	GND
A7	TEMSE
A8	TEMSB
A9	GND
B1	I+
B2	GND
B3	RESET
B4	+1.2
B5	GND
B6	+2.7
B7	GND
B8	TESTA
B9	+2.7
C1	I-
C2	GND
C3	GND
C4	DATAO
C5	GND
C6	TESTB
C7	GND
C8	+2.7
C9	+1.2

D1	Q+
D2	+1.2
D3	+2.7
D4	GND
D5	TESTC
D6	TESTD
D7	+2.7
D8	GND
D9	GND
E1	Q-
E2	DATAI
E3	GND
E4	+2.7
E5	GND
E6	TESTE
E7	GND
E8	+2.7
E9	GND
F1	GND
F2	EN
F3	CLK
F4	GND
F5	GND
F6	GND
F7	+2.7
F8	GND
F9	GND

G1	GND
G2	+1.2
G3	GND
G4	GND
G5	GND
G6	GND
G7	GND
G8	+1.2
G9	+2.7
H1	+2.7
H2	GND
H3	+2.7
H4	GND
H5	GND
H6	GND
H7	+2.7
H8	GND
H9	+2.7
J1	GND
J2	+2.7
J3	+1.2
J4	GND
J5	+2.7
J6	GND
J7	+1.2
J8	+2.7
J9	GND

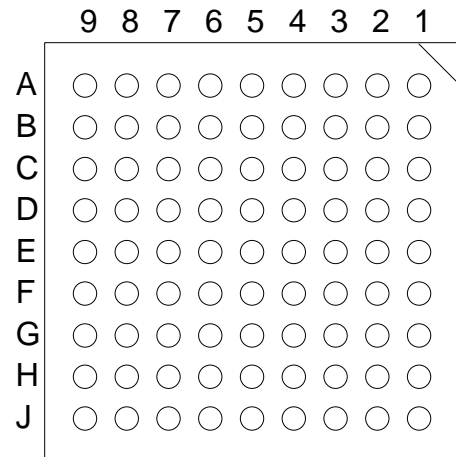

Bottom View

Pin-Out List

Power and Signal Specifications

Parameter	Pin Name	Min	Typ	Max	Unit	Comment
Reference Clock	RCLK+, RCLK-	-3	0	+3	dBm	100 ohm differential 285.714 MHz
I/Q Baseband Output	I+, I-, Q+, Q-		100		mVPP	100 ohm differential
Digital Control Inputs	RESET, CLK, DATAI, ENABLE	TBD	1.2	TBD	V	1.2V CMOS Note 1
Digital Control Output	DATAO	TBD	1.2	TBD	V	1.2V CMOS Note 1
+1.2	+1.2	1.14	1.2	1.26	V	A2,B4,C9,D2,G2,G8, J3, J7
+2.7	+2.7	2.57	2.7	2.83	V	B6,B9,C8,D3,D7,E4,E8 F7,G9,H1,H3,H7,H9,J2 J5,J8
+1.2 supply current			11		mA	
+2.7 supply current			195		mA	

Note 1
Serial digital protocol and
control registers definition
provided in the Vubiq
Programming Addendum

Performance Specifications

Parameter	Min	Typ	Max	Unit	Comment
Gain	56		70	dB	IF Atten and BB Adj
IF Gain Adjustment Range		20		dB	IF Atten adjustment
IF Filter Q Tuning Range	800		1500	MHz	IF Filter Q adjustment
System Noise Figure			5	dB	Note 1
Image Rejection		>30		dB	
P1dB		-23		dBm	Includes antenna gain Note 2
IIP3		-16		dBm	Includes antenna gain Note 2
Phase Noise		-113		dBc/Hz	10 MHz
I/Q Balance Phase		+/- 2		degrees	
I/Q Balance Amplitude		+/- 0.5		dB	
Antenna Gain		14		dBi	Inclusive of radome
Antenna Beam Width - Azimuth		53		degrees	Note 3
Antenna Beam Width - Elevation		21		degrees	Note 3

Note 1
System noise figure
includes transmission line
and coupling losses

Note 2
P1dB and IIP3 quoted for
maximum gain settings

Note 3
See azimuth and elevation
beam patterns on page 6

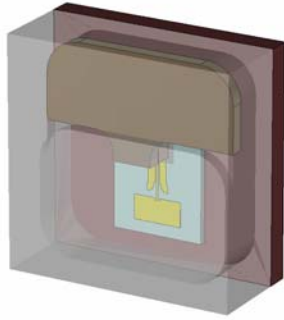

Internal View as Seen Through Radome

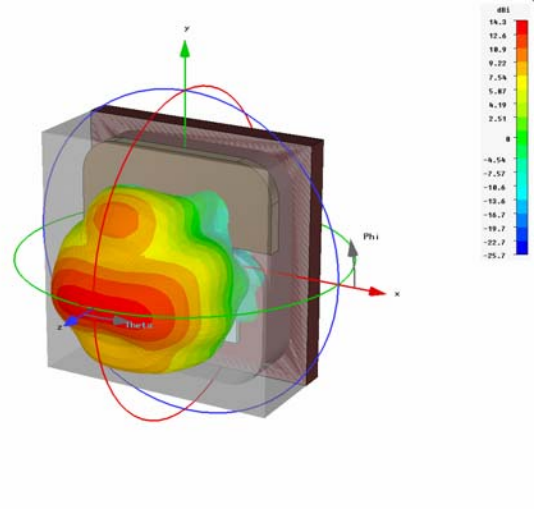

3D Radiation Pattern

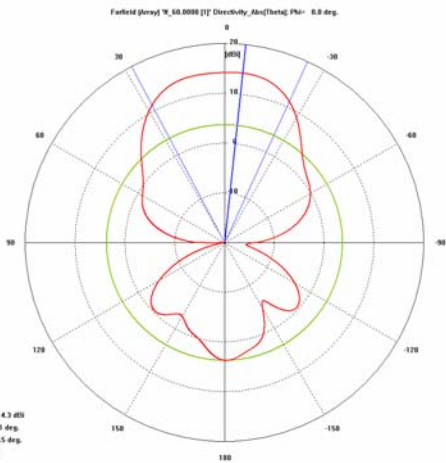

Azimuth Pattern

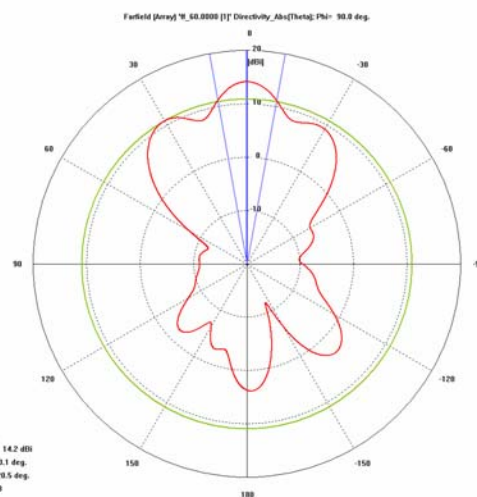

Elevation Pattern