

Technical Overview

Features

- Complete millimeter wave receiver
- WR-15, UG-385/U flange
- Operates in the 57 to 64 GHz unlicensed band
- 6 dB noise figure
- > 500 MHz baseband channels
- I/Q, AM, FM detectors
- > 1.5 GHz detection bandwidth at 60 GHz
- On chip synthesizer covers 57.0 to 63.0 GHz with 0.5 GHz step size
- Reference clock 285.714 MHz
- Samtec ST4-20 interface connector for power, digital control, baseband and reference clock

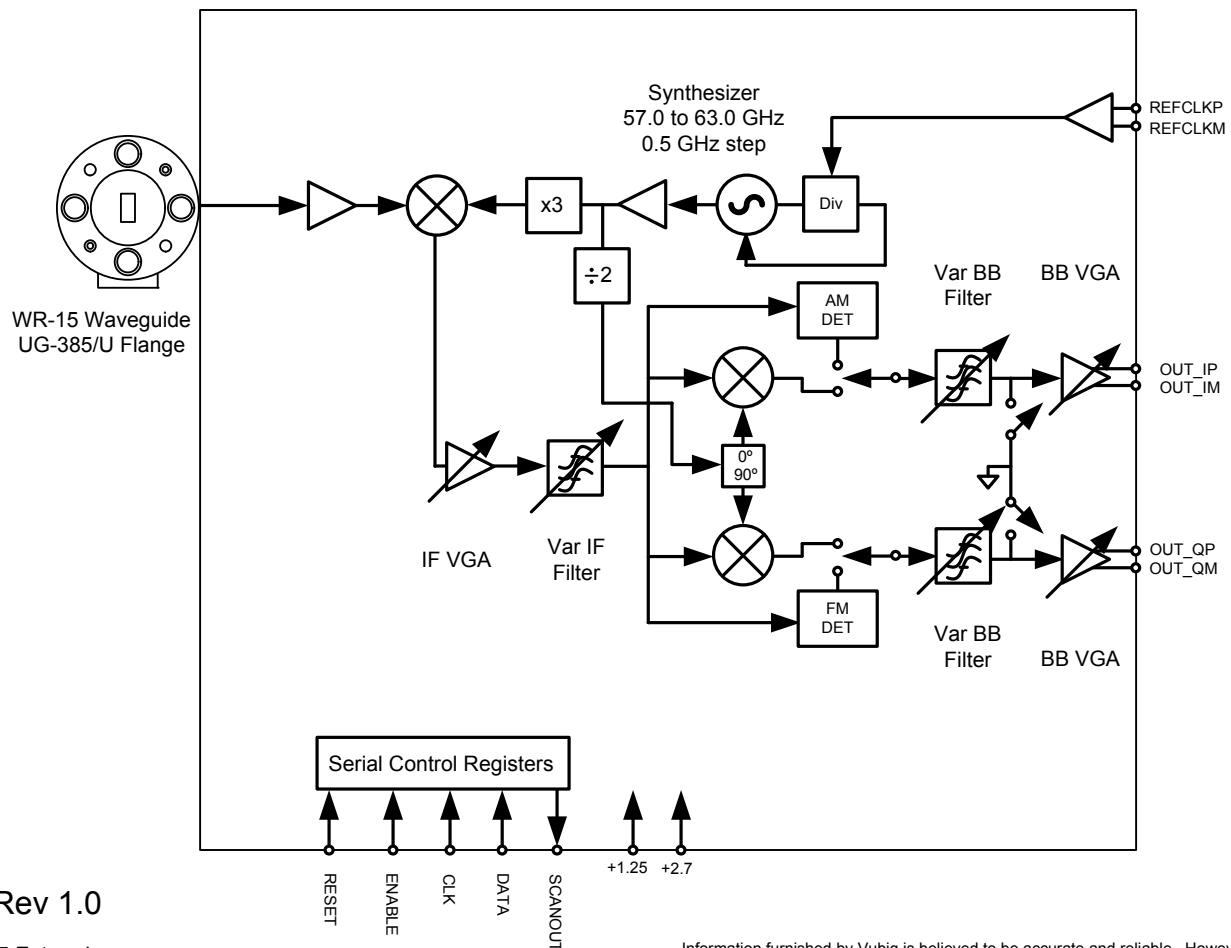
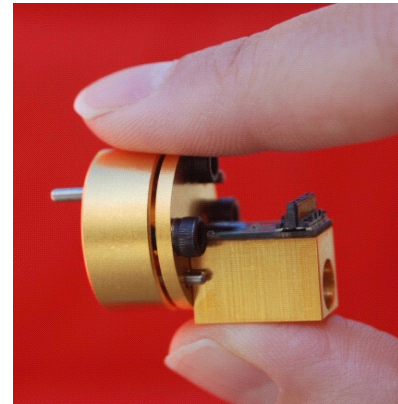

Rev 1.0

65 Enterprise
 Aliso Viejo, CA 92656, U.S.A
 Telephone 949-226-8482
 FAX 815-572-0386

www.vubiq.com
 © 2010 Vubiq, Inc. All rights reserved.

Information furnished by Vubiq is believed to be accurate and reliable. However, no responsibility is assumed by Vubiq for its use, nor for any infringements of patents or other rights of third parties that may result from its use. Specifications subject to change without notice. No license is granted by implication or otherwise under any patent or patent rights of Vubiq. Trademarks and registered trademarks are the property of their respective owners.

Dimensions

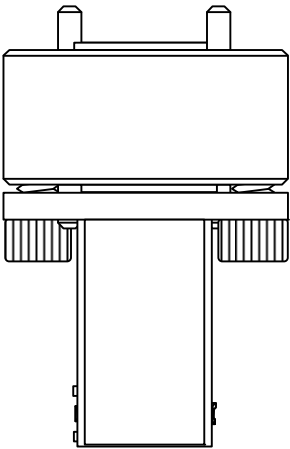

WR-15 UG-385/U Flange

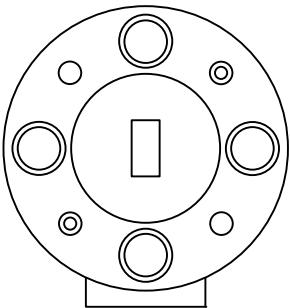

Samtec ST4-20 Connector

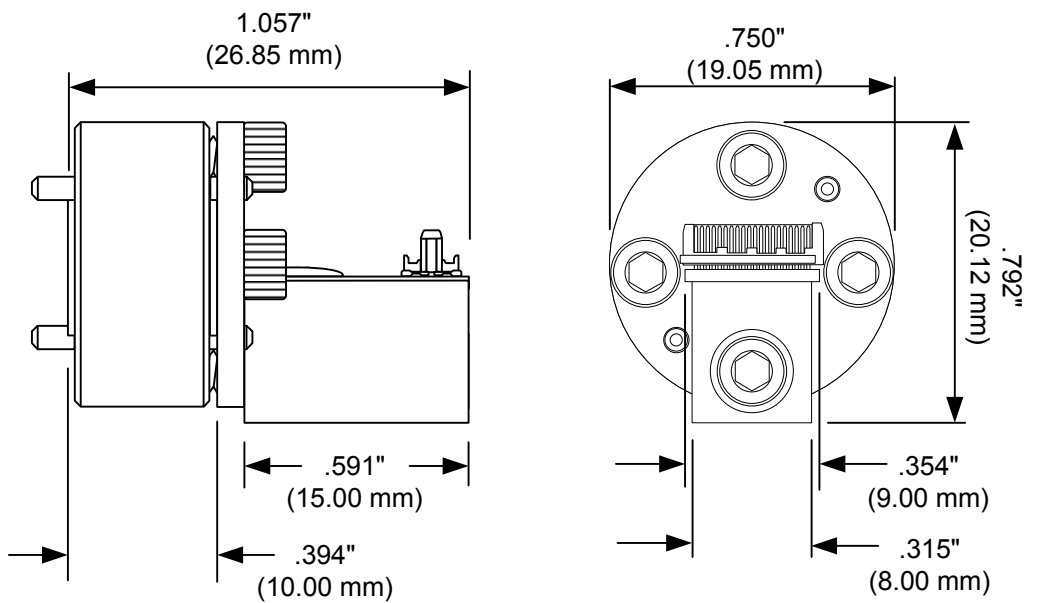
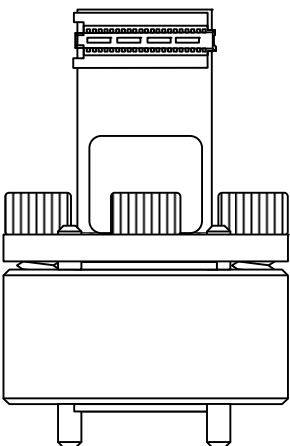

Samtec ST4-20

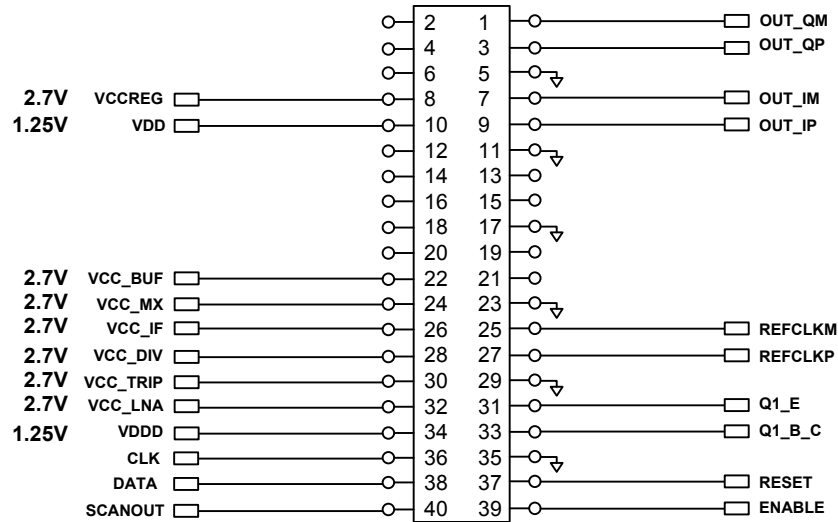

Mating Connector:
Samtec SS4-20-3.00-L-D-K-TR

Power and Signal Specifications

Parameter	Pin Name	Min	Typ	Max	Unit	Comment
Reference Clock	REFCLKM REFCLKP	-3	0	+3	dBm	100 ohm differential 285.714 MHz
I/Q Baseband Output	OUT_IP, OUT_IM OUT_QP, OUT_QM		100		mVPP	100 ohm differential
Digital Control Inputs	RESET, CLK, DATA, ENABLE		1.25		V	1.25V CMOS
Digital Control Output	SCANOUT		1.25		V	1.25V CMOS
+1.25	+1.25	1.19	1.25	1.31	V	
+2.7	+2.7	2.57	2.7	2.83	V	
+1.25 supply current			11		mA	
+2.7 supply current			195		mA	
Temperature Sensor	Q1_E Q1_B_C					2N3904 connected as diode (E, B-C)

Performance Specifications

Parameter	Min	Typ	Max	Unit	Comment
Gain	56		70	dB	IF Atten and BB Adj
IF Gain Adjustment Range		20		dB	IF Atten adjustment
IF Filter Q Tuning Range	800		1500	MHz	IF Filter Q adjustment
Noise Figure		5.5	7	dB	
Image Rejection		>30		dB	
P1dB		-37		dBm	
IIP3		-30		dBm	
Phase Noise		-113		dBc/Hz	10 MHz
I/Q Balance Phase		+/- 3		degrees	
I/Q Balance Amplitude		+/- 1		dB	