

Technical Overview

Features

- Complete millimeter wave transmitter and antenna
- 57 to 64 GHz unlicensed band
- 10 mW EIRP output power
- > 500 MHz baseband channels (I/Q, FM, AM)
- > 1.5 GHz modulated bandwidth at 60 GHz
- On chip synthesizer covers 57.0 to 64.0 GHz with 0.5 GHz step size – 15 channels
- Reference clock 285.714 MHz
- Internal high efficiency antenna
- Antenna gain 8 dBi, 65° Az-EI beamwidth
- Low-loss millimeter wave radome
- 81-pin BGA package – 10 mm x 10 mm x 4 mm

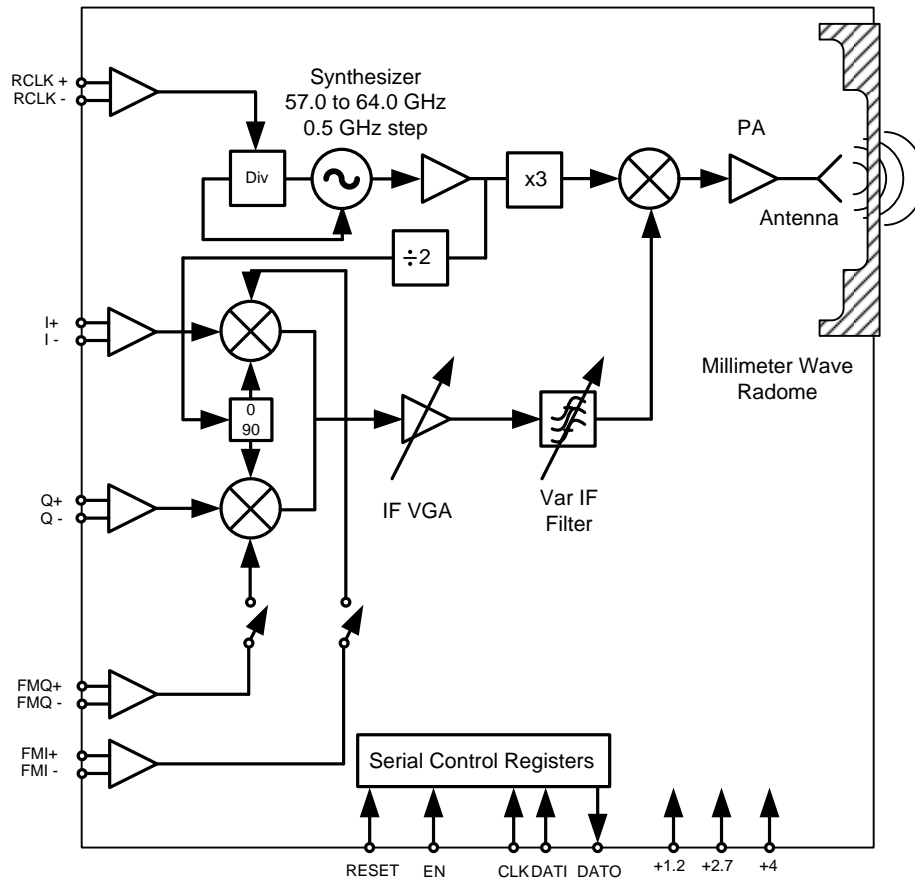

Rev 1.3

65 Enterprise
Aliso Viejo, CA 92656, U.S.A
Telephone 949-226-8482
FAX 815-572-0386

www.vubiq.com
© 2008 Vubiq, Inc. All rights reserved.

Information furnished by Vubiq is believed to be accurate and reliable. However, no responsibility is assumed by Vubiq for its use, nor for any infringements of patents or other rights of third parties that may result from its use. Specifications subject to change without notice. No license is granted by implication or otherwise under any patent or patent rights of Vubiq. Trademarks and registered trademarks are the property of their respective owners.

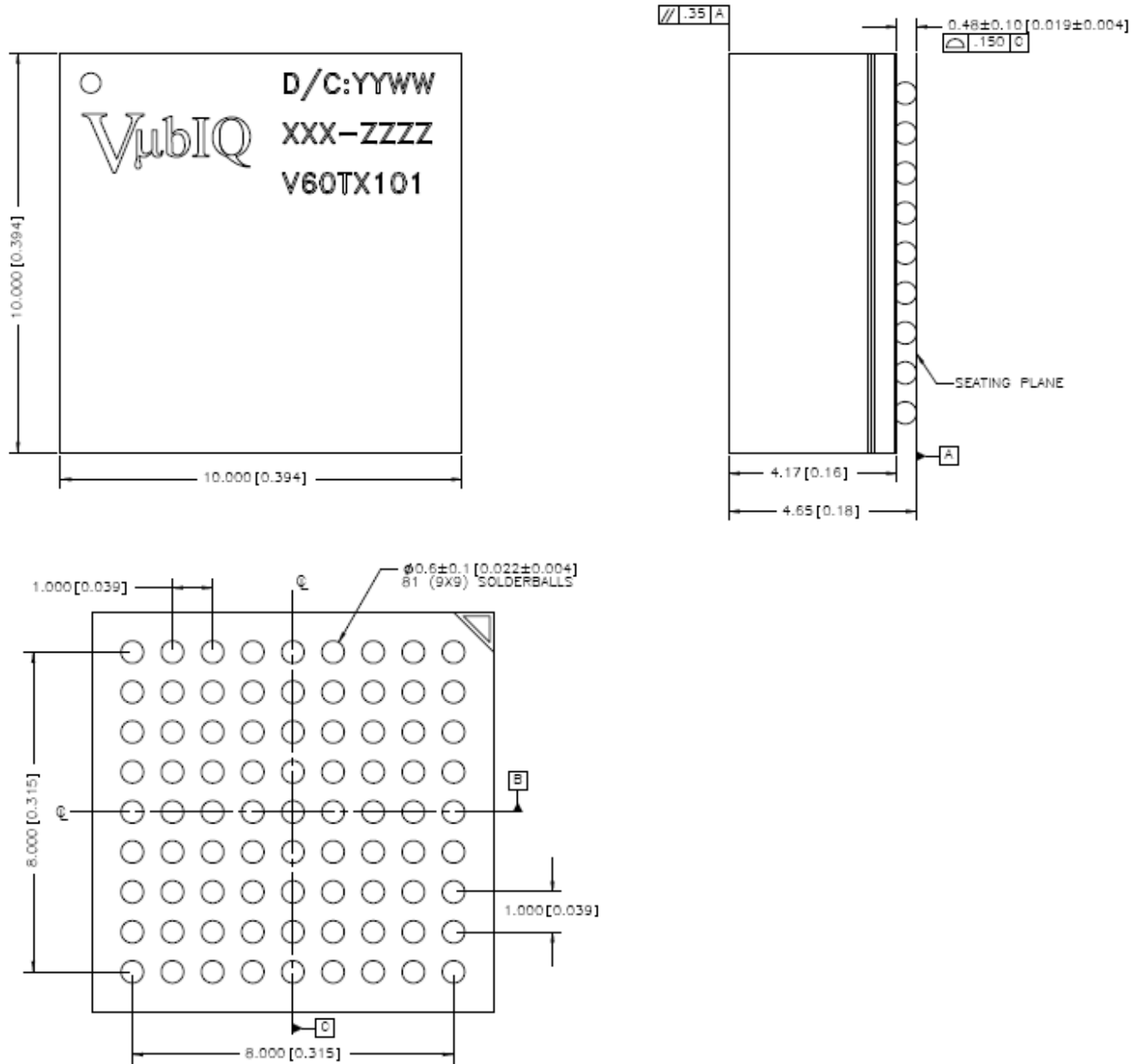

BGA Package Dimensions

A1	GND
A2	+1.2
A3	+2.7
A4	GND
A5	RCLK-
A6	RCLK+
A7	GND
A8	TEMSB
A9	TEMSE
B1	FMI+
B2	GND
B3	N/C
B4	+1.2
B5	TSTA
B6	TSTB
B7	GND
B8	+2.7
B9	GND
C1	FMI-
C2	N/C
C3	FMQ+
C4	GND
C5	TSTC
C6	TSTD
C7	GND
C8	+2.7
C9	GND

D1	I+
D2	GND
D3	FMQ-
D4	GND
D5	CLK
D6	DATAI
D7	RESET
D8	+1.2
D9	EN
E1	I-
E2	GND
E3	Q+
E4	+2.7
E5	+1.2
E6	+2.7
E7	GND
E8	DATAO
E9	GND
F1	GND
F2	GND
F3	Q-
F4	GND
F5	GND
F6	GND
F7	+4
F8	+2.7
F9	+2.7

G1	+2.7
G2	+4
G3	+2.7
G4	GND
G5	GND
G6	GND
G7	GND
G8	+2.7
G9	+4
H1	GND
H2	+2.7
H3	GND
H4	GND
H5	GND
H6	GND
H7	GND
H8	+2.7
H9	GND
J1	GND
J2	+4
J3	GND
J4	GND
J5	+4
J6	+2.7
J7	GND
J8	+4
J9	GND

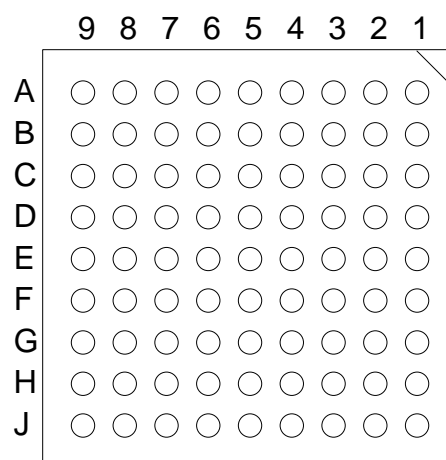

Bottom View

Pin-Out List

Power and Signal Specifications

Parameter	Pin Name	Min	Typ	Max	Unit	Comment
Reference Clock	RCLK+, RCLK-	-3	0	+3	dBm	100 ohm differential 285.714 MHz
I/Q Baseband Input	I+, I-, Q+, Q-		100		mVPP	100 ohm differential
FM Baseband Input	FMI+, FMI-, FMQ+, FMQ-		100		mVPP	100 ohm differential
Digital Control Inputs	RESET, CLK, DATAI, ENABLE	TBD	1.2	TBD	V	1.2V CMOS Note 1
Digital Control Output	DATAO	TBD	1.2	TBD	V	1.2V CMOS Note 1
+1.2	+1.2	1.14	1.2	1.26	V	A2,B4,D8,E5
+2.7	+2.7	2.57	2.7	2.83	V	A3,B8,C8,E4,E6,F8,F9, G1,G3,G8,H2, H8,J6
+4	+4	3.8	4.0	4.2	V	F7,G2,G9,J2,J5,J8
+1.2 supply current			11		mA	
+2.7 supply current			190		mA	
+4 supply current			70		mA	

Note 1
Serial digital protocol and
control registers definition
provided in the Vubiq
Programming Addendum

Performance Specifications

Parameter	Min	Typ	Max	Unit	Comment
Gain		35		dB	Referenced to baseband input
IF Gain Adjustment Range		20		dB	IF Atten adjustment
IF Filter Q Tuning Range	800		1500	MHz	IF Filter Q adjustment
PA Output P1db	-2	0	+3	dBm	Note 1
PA Output Psat		+5		dBm	
Image Rejection		-25		dBc	
Carrier Suppression		-23		dBc	Note 3
3x LO Spur		-25		dBc	
Phase Noise		-113		dBc/Hz	10 MHz from carrier
I/Q Balance Phase		+/- 2		degrees	
I/Q Balance Amplitude		+/- 0.5		dB	
Antenna Gain		8.1		dBi	Inclusive of radome
Radiated EIRP	+5.1	+8.1	+11.1	dBm	Inclusive of radome
Antenna Beam Width - Azimuth		65		degrees	Note 2
Antenna Beam Width - Elevation		63		degrees	Note 2

Note 1
Higher output power will be available in Q4 2008

Note 2
See azimuth and elevation beam patterns on page 6

Note 3
Carrier suppression is relative to modulated output power

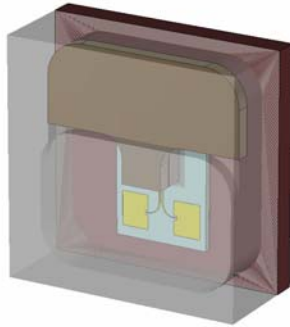

Internal View as Seen Through Radome

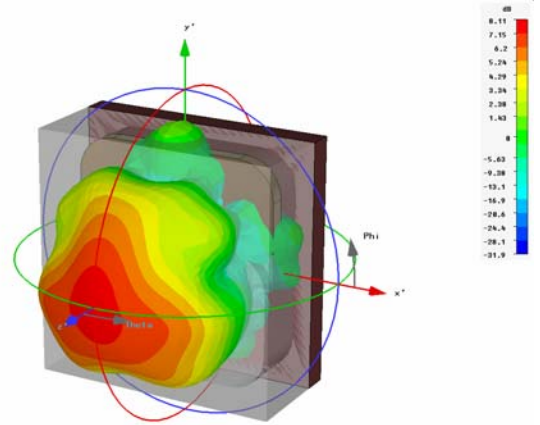

Type	Farfield
Approximation	multibed (3D > 1)
Monitor	ff_60.0000 [1]
Component	Mag
Output	Gain
Frequency	60
Rad. effic.	0.9711
tot. effic.	0.9629
Gain	9.195 dB

3D Radiation Pattern

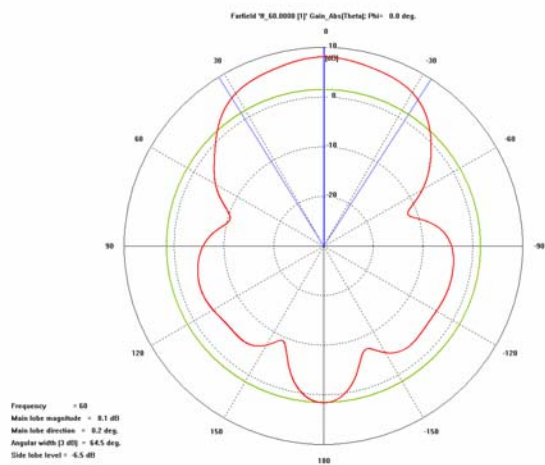

Azimuth Pattern

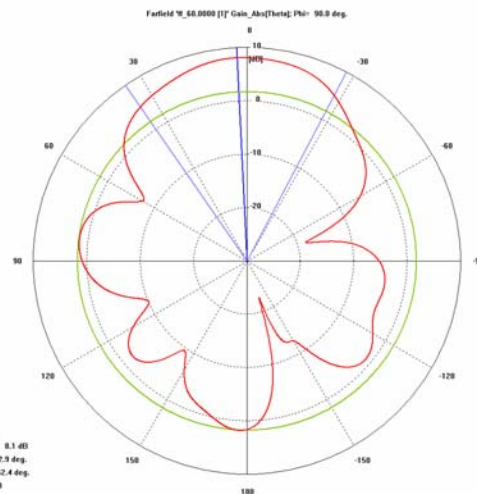

Elevation Pattern